

**ICC Evaluation Service, Inc.**  
[www.icc-es.org](http://www.icc-es.org)

Business/Regional Office ■ 5360 Workman Mill Road, Whittier, California 90601 ■ (562) 699-0543  
 Regional Office ■ 900 Montclair Road, Suite A, Birmingham, Alabama 35213 ■ (205) 599-9800  
 Regional Office ■ 4051 West Flossmoor Road, Country Club Hills, Illinois 60478 ■ (708) 799-2305

**DIVISION: 09—FINISHES**  
**Section: 09120—Ceiling Suspension**  
**Section: 09130—Acoustical Suspension**

**REPORT HOLDER:**

**WORTHINGTON ARMSTRONG VENTURE (WAVE)**  
**9 OLD LINCOLN HIGHWAY, SUITE 200**  
**MALVERN, PENNSYLVANIA 19355**  
**(610) 722-1218**  
[www.armstrong.com](http://www.armstrong.com)  
[jikelly@armstrong.com](mailto:jikelly@armstrong.com)

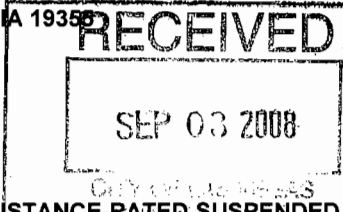

**EVALUATION SUBJECT:**

**FIRE- AND NONFIRE-RESISTANCE-RATED, SUSPENDED  
 CEILING FRAMING SYSTEMS**

**ADDITIONAL LISTEES:**

**ARMSTRONG WORLD INDUSTRIES**  
**POST OFFICE BOX 3001**  
**LANCASTER, PENNSYLVANIA 17604**

**1.0 EVALUATION SCOPE**

**Compliance with the following codes:**

- 2003 *International Building Code*® (IBC)
- 1997 *Uniform Building Code*™ (UBC)

**Properties evaluated:**

- Interior finish
- Fire resistance
- Structural

**2.0 USES**

The Worthington Armstrong Venture (WAVE) ceiling framing systems described in this report are suspended, exposed framing, ceiling assemblies used in fire-resistance-rated and nonfire-resistance-rated construction for interior applications.

**3.0 DESCRIPTION**

**3.1 Grid Components:**

**3.1.1 Main Runners, Nonfire-resistance-rated:** Main runners for use in nonfire-resistance-rated ceiling assemblies include the 6100, 6500, AL7200, SS7200, 7300, 7500, 7600, and 76008 series. All members are classified as intermediate-duty in accordance with ASTM C 635-97 (IBC) and Table 25-2-A of UBC Standard 25-2 (UBC), except the following, which are classified as heavy-duty: 7301, 7501, 7601, 7604, 7605, 76018, 76048 and 76058. Profiles of runners are shown in Figure 1.

The 6100, 7300, 7500, 7600, and 76008 runners are cold-formed from ASTM A 568 steel. The runners have a hot-dipped galvanized coating and a factory-installed polyester-painted steel cap or aluminum cap along the entire length of the bottom flange. The 6100 and 7600 series have a painted coating in addition to the hot-dipped galvanized coating, and have no cap. The 6500 series runners are cold-formed from 6063-T6 aluminum and have a baked polyester paint coating. The AL 7200 runners are cold-formed from 3003-H14 aluminum and have a baked polyester paint coating. The SS 7200 runners are cold-formed from 300 series stainless steel complying with ASTM A 480. Table 2 specifies dimensions, lengths, and allowable transverse loads.

**3.1.2 Cross Runners, Nonfire-resistance-rated:** Cross runners for use in nonfire-resistance-rated ceiling assemblies are the 6100 (Interlude), XL 6500 (Sonata), XL 7100 (Prelude), XLAL 7200 (Prelude Aluminum), XLSS 7200 (Prelude Stainless), XL 7300 (Prelude), XL 7500 (Suprafine), XL 7600 (Silhouette), and XL 76008 (Silhouette) series.

The XL 6100, XL 7100, XL 7300, XL 7500, XL 7600 and XL 76008 cross runner members are cold-formed from ASTM A 568 steel. The cross runners have a hot-dipped galvanized coating and a factory-installed polyester-painted steel cap or aluminum cap along the entire length of the bottom flange. The XL 6100 and XL 7600 and XL 76008 series have a baked polyester painted coating in addition to the hot-dipped galvanized coating, and have no cap. The 6500 runners are cold-formed from 6063-T6 aluminum and have a baked polyester paint coating. The XLAL 7200 runners are cold-formed from 3003-H14 aluminum and have a baked polyester paint coating. The XLSS 7200 runners are cold-formed from 300 series stainless steel complying with ASTM A 480. Table 3 specifies dimensions, lengths, and allowable transverse loads.

**3.1.3 Main Runners, Fire-resistance-rated:** Main runners for use in fire-resistance-rated ceiling assemblies are the HD 8201, 8300, 8301, 8500 and 8501 runners listed in Table 2. The 8300 and 8500 runners are classified structurally as intermediate-duty in accordance with ASTM C 635 and Table 25-2-A of UBC Standard 25-2; Models 8301, 8501, and HD 8201 main runners are classified structurally as heavy-duty. Profiles of runners are shown in Figure 1.

All members have an inverted T-shape. Members are cold-formed from ASTM A 568 steel with a hot-dipped galvanized coating.

Models 8300, HD 8201 and 8301 have a factory-installed steel cap along the entire length of the bottom flange. The HD 8201 member has a hot-dipped galvanized coating and a bottom flange cap made from either 3003-H16 or 3105-H16 aluminum. Table 2 specifies dimensions, lengths and allowable transverse loads.

**3.1.4 Cross Runners, Fire-resistance-rated:** Cross runners for use in fire-resistance-rated ceiling assemblies are

\*Corrected August 2006

**ES REPORTS™** are not to be construed as representing aesthetics or any other attributes not specifically addressed, nor are they to be construed as an endorsement of the subject of the report or a recommendation for its use. There is no warranty by ICC Evaluation Service, Inc., express or implied, as to any finding or other matter in this report, or as to any product covered by the report.



the XL 8200 (Prelude Plus Fire Guard), XL 8300 series (Prelude Fire Guard), and XL 8500 (Prelude Suprafine Fire Guard) series runners listed in Table 3. Profiles of runners are shown in Figure 1. Members are cold-formed from ASTM A 568 steel with a hot-dipped galvanized coating. The XL 8300 and XL 8500 series have a factory-installed steel cap along the entire length of the bottom flange. The XL 8200 series members have a hot-dipped galvanized coating and a bottom flange cap made from either 3003-H16 or 3105-H-16 aluminum. Table 3 specifies dimensions, lengths and allowable transverse loads.

**3.1.5 Materials:** Prior to coating, the minimum yield strengths are 48 ksi (330.7 MPa) for 0.010-inch-thick (0.25 mm) steel, 50 ksi (344.5 MPa) for 0.013-inch-thick (0.33 mm) steel, 51 ksi (351.4 MPa) for 0.015-inch-thick (0.38 mm) steel, and 54 ksi (372.1 MPa) for 0.018-inch-thick (0.45 mm) steel. After forming, the steel runners have a minimum yield strength of 63 ksi (434 MPa). The 6500 series runners of 6063-T6 aluminum have a minimum yield strength of 30,000 psi (207 MPa). The AL 7200 Series runners of 3003-H14 aluminum have a minimum yield strength of 27,200 psi (187 MPa).

### 3.2 Hanger Wire:

Hanger wire for suspended ceilings, and any fixtures, shall comply with IBC Section 2506.2.1 or UBC Table 25-A.

### 3.3 BERC-2 Clip:

The BERC-2 (Beam End Retaining Clip System) is illustrated in Figure 2. It is used to connect main and cross runners to wall molding. The clip is manufactured from 0.034-inch-thick (0.864 mm) hot-dipped galvanized cold-rolled steel complying with ASTM A 568.

### 3.4 Accessories:

Each framing system has accessory items that include support angles and corner caps. Steel for accessory items has a minimum yield strength of 33 ksi (227 MPa).

## 4.0 DESIGN AND INSTALLATION

### 4.1 General:

The suspended ceiling framing system shall be installed in accordance with this report and the manufacturer's published installation instructions. The suspended ceiling framing system shall be installed in accordance with IBC Section 803.9.1.1 or UBC Table 25-A for systems exceeding 4 psf but less than 10 psf, as applicable.

### 4.2 Main Runners:

Main runners shall be installed and leveled to within  $\frac{1}{4}$  inch in 10 feet (6.4 mm in 3048 mm) (IBC) or  $\frac{1}{8}$  inch in 12 feet (3.2 mm in 3660 mm) (UBC), with the supporting wire taut. Vertical support hanger wire shall be installed within 3 inches (51 mm) of the main runner fire expansion relief. The design loads for main runners shall be less than or equal to the capacities allowed in Table 2 of this report. Supports for the main runners that consist of vertical hangers, perimeter hangers, and lateral force bracing shall be installed in accordance with the applicable code.

### 4.3 Cross Runners:

Main runners, or other cross runners, shall support cross runners to within  $\frac{1}{32}$  inch (0.80 mm) of the required center-to-center spacing. This tolerance shall be noncumulative beyond 12 feet (3658 mm). Intersecting runners shall be installed to form a right angle to the supporting members.

The maximum design load capacities for cross runners shall be less than or equal to the capacities allowed in Table 3 of this report. A cross runner that supports another cross member shall have a minimum uniformly distributed load capacity of 12 pounds per linear foot (175 N/m).

## 4.4 Seismic Design:

### 4.4.1 Seismic Design Requirements under the IBC:

Seismic design and installation details of the ceiling system shall be in accordance with IBC Section 1621, except as noted in Section 4.4.3 of this report. In areas enforcing the IBC, systems classified as intermediate-duty are limited to use in Seismic Design Categories A, B and C.

### 4.4.2 Seismic Design Requirements under the UBC:

Seismic design and installation details of the ceiling system shall be in compliance with Part III of UBC Standard 25-2, except as noted in Section 4.4.3 of this report.

### 4.4.3 BERC-2 Clip:

#### 4.4.3.1 Alternate Seismic Design Category D, E and F

**Installation:** Under this installation, the runners must be rated heavy-duty and have a minimum simple span uniform load of 16.35 pounds per lineal foot (238 N/m); maximum ceiling weight permitted is 1.80 pounds per square foot (8.78 kg/m<sup>2</sup>). The BERC-2 clip is used to secure the main runners and cross runners on two adjacent walls to the structure and the two opposite walls to the perimeter trim, as detailed below and shown in Figure 2. A nominally  $\frac{7}{8}$ -inch (22 mm) wall molding is used in lieu of the 2-inch (51 mm) perimeter supporting closure angle required by Section 9.6.2.6.2.2 (b) of ASCE-7 for Seismic Design Categories D, E and F. Except for the use of the BERC-2 clip and the  $\frac{7}{8}$ -inch (22 mm) wall molding and elimination of spreader bars, installation of the ceiling system must be as prescribed by the applicable code.

The BERC-2 clip is attached to the wall molding by sliding the locking lances over the hem of the vertical leg of the wall molding. Clips installed on the walls where the runners are fixed are attached to the runner by a sheet metal screw through the horizontal slot in the clip into the web of the runner. Clips installed on the walls where the runners are not fixed to the clips allow the terminal runner end to move  $\frac{3}{4}$  inch (19.1 mm) in both directions. BERC-2 clips installed in this manner are an acceptable means of preventing runners from spreading in lieu of spacer bars required in CISCA 3-4, which is referenced in ASCE 7, Section 9.6.2.6.2.2, which is referenced in IBC Section 1621. See Figure 2.

#### 4.4.3.2 Alternate Seismic Design Category C Installation:

Terminal ends of the runners are secured by attaching the BERC-2 clip to the wall molding and attaching the runners to the BERC-2 clip. The runners have zero clearance at the perimeter on two adjacent walls and  $\frac{3}{8}$ -inch (9.5 mm) clearance on the opposite walls. The clip is attached to the wall molding by sliding the locking lances over the hem of the vertical leg of the wall molding. BERC-2 clips installed in this manner are an acceptable means of preventing runners from spreading, in lieu of spacer bars required in CISCA 0-2, which is referenced in ASCE 7, Section 9.6.2.6.2.1, which is referenced in IBC Section 1621. Except for the use of the BERC-2 clip as noted above, installation of the ceiling system must be as prescribed by the applicable code. Maximum ceiling weight permitted is 1.20 pounds per square foot (5.86 kg/m<sup>2</sup>). This construction is equivalent to that required by CISCA 0-2, which is referenced in ASCE-7, Section 9.2.6.2.1, which is referenced in IBC Section 1621; and by UBC Standard 25-2.

### 4.5 Partitions:

Partitions must be laterally supported as required by IBC Section 1621 or UBC Standard 25-2, Section 25.211.1, as applicable.

### 4.6 Two-hour Fire-resistance-rated Floor-ceiling Assembly:

The following floor-ceiling assembly has a two-hour fire-resistance rating (refer to Figure 3 for details):

**4.6.1 Structural Beams:** The structural floor beams supporting the floor-ceiling assembly are minimum W8×15, or an equivalent-sized steel beam having a minimum weight-to-heated-perimeter ratio, W/D, of 0.54.

In accordance with Section 714.2 of the IBC or Section 704.2.6 of the UBC, structural steel floor beams need not be individually fire-protected when the suspended ceiling forms the protective membrane for the fire-resistance-rated assembly. Structural floor beams must be individually protected on all sides for the full length with materials having the required fire-resistance rating, however, when they support directly applied loads from a floor and roof or more than one floor, or where the required fire-resistance rating of such members is greater than two hours.

**4.6.2 Floor Joists:** Floor joists are minimum 10K1 steel bar joists, spaced a maximum of 24 inches (610 mm) on center. Each joist must be welded to end supports, and must have  $\frac{1}{2}$ -inch-diameter (12.7 mm) steel bar bridging members welded to top and bottom chords of each joist at midspan.

**4.6.3 Steel-floor Decking:** The concrete deck is either supported by minimum No. 22 gage [0.0299 inch (0.759 mm)] galvanized steel decking with  $1\frac{19}{32}$ -inch-deep (32.5 mm) flutes spaced 6 inches (152 mm) on center, or is supported by minimum No. 20/20 gage [0.0359 inch (0.91 mm)] galvanized steel cellular units having 3-inch-deep (76 mm) flutes.

When a blend of fluted and cellular steel units is used, the concrete topping thickness is measured from the top plane of the cellular units. The steel decking shall be welded to supports at 12 inches (305 mm) on center. Adjacent units must be button-punched or welded together at 36 inches (914 mm) on center at side joints.

Where fluted and cellular floor units are installed end-to-end, galvanized steel angles must be tack-welded to the cellular floor units in such a manner as to cover the cells.

**4.6.4 Concrete Floor:** The concrete floor must be a minimum of  $2\frac{1}{2}$  inches (63.5 mm) thick, measured from the top of the metal decking, and normal-weight concrete with carbonate or siliceous aggregates. The concrete must have a minimum density of  $150 \pm 3$  pcf ( $2400 \pm 48$  kg/m<sup>3</sup>), and a minimum compressive strength of 3,000 psi (20.7 MPa). The middle of the slab must be reinforced with 6×6-W1.4×W1.4 welded wire fabric.

#### 4.6.5 Suspended Ceiling Members:

**4.6.5.1 Main Runners:** Main runners are either the 8300, 8301 or HD 8201. The main runners are 12 feet (3657.6 mm) long and spaced a maximum of 4 feet (1219.2 mm) on center. The design loads for main runners must be less than or equal to the capacities shown in Table 2. Vertical hangers, perimeter hangers, and lateral-force bracing for the main runners are installed in accordance with the code. The distance from the bottom side of the floor decking to the bottom side of the main runners is a minimum of  $19\frac{3}{4}$  inches (502 mm).

**4.6.5.2 Cross Runners:** Cross runners are either the XL 8200 series (Prelude Plus Fire Guard) or XL 8300 series (Prelude Fire Guard). Main runners must be located within  $\frac{1}{32}$  inch (0.79 mm) of the required center distances, and this tolerance must be noncumulative beyond 12 feet (3657.6 mm). Intersecting runners must be installed to form a right angle to the supporting members. The design loads for cross runners must be less than or equal to the capacities shown in Table 3. A cross runner that supports another cross member must have a minimum uniformly distributed load capacity of 12 pounds per linear foot (175 N/m).

**4.6.5.3 Hanger Wire:** The suspended ceiling is supported by No. 12 SWG [0.105 inch (2.7 mm) in diameter] galvanized

steel wire that is attached to the concrete slab through the steel floor units, before concrete placement, or attached to hanger clips. The hanger clips are minimum 0.045-inch-thick (1.14 mm), 2-inch-wide (51 mm),  $3\frac{1}{2}$ -inch-long (90 mm), galvanized steel clips that are hooked at one end, for attachment over the male leg of steel floor units, and spaced as required for hanger wire attachment.

Hanger wires are spaced a maximum of 48 inches (1219 mm) on center or shall be located at every other main runner/cross-tee intersection, whichever dimension is less along main runners. Hanger wire must be located at all four corners of light fixtures, at mid-span of cross tees next to 4- and 5-foot-long (1219 and 1524 mm) light fixtures and air duct outlets, and next to each main runner splice. Additional hanger wires are required at the mid-span of those cross tees running parallel and nearest to the walls and those near the end of cut cross tees longer than 2 feet (610 mm) that abut walls.

**4.6.6 Acoustical Material:** Acoustical lay-in ceiling panels used with the suspended ceiling system are the nominal panel sizes and types shown in Table 1. Panels are nominally  $\frac{5}{8}$  inch (15.9 mm) or  $\frac{3}{4}$  inch (19.1 mm) thick. Border panels are supported at walls by 24 MSG painted steel channels, 1 inch (25 mm) deep, with a 2-inch (23.8 mm) bottom flange. Optional support method consists of BERC-2 clip at wall attached to  $\frac{15}{16}$  inch ×  $\frac{15}{16}$  inch No. 24 MSG painted steel channels.

**4.6.7 Hold-down Clips:** Hold-down clips, produced from No. 24 gage spring steel, must be used for ceiling panels weighing less than one pound per square foot. When the ceiling is composed of nominally 24-by-24-inch (610 by 610 mm), 24-by-36-inch (610 by 914 mm), or 30-by-30-inch (762 by 762 mm) lay-in panels, one clip is placed over bulbs of cross tees near cross tee midpoints. When the ceiling is composed of 20-by-60 inch (508 by 1524mm), 36-by-36-inch (914 by 914 mm), 24-by-48-inch (610 by 1219 mm), 30-by-60-inch (762 by 1524 mm), 36-by-60-inch (914 by 1524 mm) or 48-by- 48-inch (1219 mm) lay-in panels, two clips are placed over bulbs of each cross tee near cross tee quarter-points. One leg of each clip is cut off when placement is over bulbs of cross tees adjacent to the long side of light fixtures.

**4.6.8 Recessed Light Fixtures:** Fluorescent-lamp-type, steel housing fixtures can be used in the fire-resistance-rated assembly, provided the fixtures measure 1 by 4 feet (305 by 1219 mm), 2 by 2 feet (610 by 610 mm), 2 by 4 feet (610 by 1219 mm), 20 by 48 inches (508 by 1219 mm) or 20 by 60 inches (508 by 1524 mm). The nominally 1-by-4-foot (305 by 1219 mm), 2-by-2-foot (610 by 610 mm) and 2-by-4-foot (610 by 1219 mm) fixtures may include vented sides for air boots and vented tops for air-return purposes. Linear air diffusers and linear air returns must be used with nominally 20-by-48-inch (508 by 1219 mm) fixtures. When nominally 20-by-60-inch (508 by 1524 mm) fixtures are used, fixture stabilizers are used to supplement the hanger wires occurring at the mid-span of the 5-foot-long (1524 mm) cross tees.

When nominally 1-by-4-foot (305 by 1219 mm) fixtures are used, the aggregate number of fixtures must not exceed four per 100 square feet (9.3 m<sup>2</sup>) of ceiling area. When nominally 2-by-2-foot (610 by 610 mm) fixtures are used, the aggregate number of fixtures must not exceed five per 100 square feet (9.3 m<sup>2</sup>) of ceiling area. When nominally 2-by-4-foot (610 by 1219 mm), 20-by-48-inch (508 by 1219 mm), or 20-by-60-inch (508 by 1524 mm) fixtures are used, the aggregate number of fixtures shall not exceed three per 100 square feet (9.3 m<sup>2</sup>) of ceiling area. The fixtures must be wired in conformance with an approved electrical code.

The recessed light fixture must be protected on the topside with acoustical ceiling tile panel material having a minimum

thickness of  $\frac{5}{8}$  inch (15.9 mm). The panels are cut into pieces to form a five-sided enclosure which is rectangular or trapezoidal in cross section, depending upon fixture type, and which is approximately  $\frac{1}{2}$  inch (12.7 mm) longer and wider than the fixture, with sufficient depth to provide at least 1 inch (12.7 mm) of clearance between the fixture and the enclosure. The pieces are held together with 8d nails. Spacers provide the  $1\frac{1}{4}$ -inch (31.7 mm) clearances when placed on top of fixtures located away from the ballasts. When no air-handling or air-return fixtures are used, a maximum  $1\frac{1}{4}$ -inch (31.7 mm) separation must be maintained between the long fixture protection sidepieces and the top piece. When air supply light fixtures with air boots are used, fixtures and air boots must be fully enclosed except for the nominally 28-square-inch (18 064 mm<sup>2</sup>) opening needed for the connection to air-supply ducts.

**4.6.9 Air Duct:** Air ducts are permitted in the assembly provided the aggregate duct opening area is less than or equal to 113 square inches (72 903 mm<sup>2</sup>) per 100 square feet (9.2 m<sup>2</sup>) of ceiling area. The maximum air duct-opening dimension is 12 inches (305 mm).

**4.7 8500 (Prelude SupraFine Fire Guard) Series One-hour Fire-resistance-rated Floor-ceiling System:**

This exposed grid system consists of the 8500 series main runners and the XL 8520 or XL 8540 cross runners, and is part of a one-hour fire-resistance-rated floor-ceiling system. The rating applies to restrained and unrestrained assemblies as described in Section 27 of ASTM E 119 and Section 7.141 of the UBC Standard 7-1. See Figure 4 for assembly details. General requirements in IBC Section 711 and UBC Section 710.1 must be observed.

**4.8 Special Inspection:**

In jurisdictions adopting the IBC, suspended ceilings in Seismic Design Categories D, E and F are subject to periodic special inspections during the anchorage of suspended ceiling systems in accordance with the requirements of IBC Section 2506.2.1 and Section 9.6.2.6.2.2 (h) of ASCE 7-02. The special inspector must verify that the ceiling system is as described in this report, and complies with the installation instructions in this report.

**5.0 CONDITIONS OF USE**

The suspended ceiling systems described in this report comply with, or are suitable alternatives to what is specified in, those codes listed in Section 1.0 of this report, subject to the following conditions:

**5.1** The ceiling suspension main runners, cross runners and BERC-2 clips are fabricated and installed in accordance with this report and the manufacturer's published installation instructions. In the event of a conflict between the manufacturer's installation instructions and this report, this report governs.

- 5.2** Allowable loads and spans of main and cross runners must comply with Tables 2 and 3 of this report.
- 5.3** In areas enforcing the UBC, ceiling access must comply with Footnote 4 to Table 16-B of the UBC.
- 5.4** In jurisdictions adopting the IBC, periodic special inspections must be provided in accordance with Section 4.8 of this report.
- 5.5** In jurisdictions adopting the IBC, a quality assurance plan for seismic requirements must be provided in accordance with IBC Section 1705.2.
- 5.6** In jurisdictions adopting the IBC, the ceiling systems must be braced to resist seismic forces as determined from Section 1621.2.5 of the IBC. In jurisdictions adopting the UBC, the suspended ceiling systems must be braced to resist seismic forces as determined from Table 16-0 of the UBC and Section 25.210 of UBC Standard 25-2.
- 5.7** In jurisdictions adopting the UBC, the ceiling systems must not be installed in areas subject to severe environmental conditions as described in Section 25.204.3 of UBC Standard 25-2.
- 5.8** The supporting construction for the ceiling system has not been evaluated and is outside the scope of this report. The code official must approve the floor or roof construction supporting the suspended ceiling system.
- 5.9** The ceiling systems are restricted to interior applications.
- 5.10** Lay-in ceiling panels must be justified to the satisfaction of the code official as complying with the interior finish requirements of Chapter 8 of the applicable code.

**6.0 EVIDENCE SUBMITTED**

- 6.1** Reports of vertical, compressive and tension load tests in accordance with ASTM C 635 and UBC Standard 25-2.
- 6.2** Reports of fire-resistance tests in accordance with ASTM E 119 (IBC Standard 7-1).
- 6.3** Reports of comparative seismic qualification tests in accordance with the ICC-ES Acceptance Criteria for Seismic Qualification by Shake-table Testing of Nonstructural Components and Systems (AC156), dated June 2004.
- 6.4** A quality control manual.

**7.0 IDENTIFICATION**

Cartons of framing members, clips and accessories are identified with the name and address of Armstrong World Industries, Inc.; the acronym "WAVE"; number designations specifying gage of steel, depth of section and length; and the evaluation report number (ESR-1308).

TABLE 1—ACOUSTICAL MATERIALS

ACOUSTICAL PANEL SIZE (inches)	ACOUSTICAL MATERIAL TYPE <sup>1</sup>	STEEL FLOOR UNIT TYPE <sup>2</sup>
20 by 60	P(S OR P) OR PC(S)	F, C or B
20 by 60	P(S OR P) OR PC(S)	F or B <sub>1</sub>
24 by 24	BF(S)	F, C or B
24 by 24	BF(S)	F
24 by 24 or 36	P(S)	F, C or B
24 by 24 or 36	PC(S)	C or B
24 by 24 or 36	P(S)	F
24 by 48 or 60	P(S OR P) OR PC(S)	F, C or B
24 by 48 or 60	P(S OR P) OR PC(S)	F or B <sub>1</sub>
30 by 30	P(S)	F, C or B
30 by 30	PC(S)	C or B
30 by 30	P(S)	F
30 by 60	P(S) OR PC(S)	F, C or B
36 by 36	PC(S)	F, C or B
36 by 36	PC(S)	F or B <sub>1</sub>
36 by 60	PC(S)	F, C or B
48 by 48	PC(S)	F, C or B

For SI: 1 inch = 25.4 mm.

<sup>1</sup>(S) = surface perforations, (P) = through perforations.

<sup>2</sup>(F) = all fluted steel units, (C) = all cellular steel floor units, (B) = any blend of fluted and cellular floor units, (B<sub>1</sub>) = blend of one cellular floor unit and one or more fluted units.

TABLE 2—DIMENSIONS AND ALLOWABLE LOADS FOR MAIN RUNNERS

CATALOG NUMBER	NOTE	TYPE (SEE FIGURE 1)	LENGTH (inches)	METAL THICKNESS (inch)	MAXIMUM SPAN (feet)	ALLOWABLE LOADS	
						Simple Span Uniform Load (lb./lin. ft.)	Concentrated Load at Midspan (lb.)
6100	1	M	144	0.013	4	12.6	25.2
6500	N/A	N	144	0.045	4	13.24	26.48
AI 7200	1	B	144	0.021	3	13.47	26.94
SS 7200	3	B	144	0.015	4	12.23	24.46
7300	1	A	144	0.010	4	13.5	27
7301	1	A	144	0.015	4	16.73	33.46
7302	1	A	120	0.010	4	13.5	27
7305	1	A	140	0.010	4	13.5	27
7500	1	H	144	0.013	4	12.75	25.5
7501	1	H	144	0.018	4	16.86	33.75
7600	1	K	144	0.013	4	13.10	26.2
76008	1	L	144	0.013	4	13.10	26.2
7601	1	K	144	0.017	4	16.35	32.70
76018	1	L	144	0.017	4	16.35	32.70
7602	1	K	120	0.013	4	13.10	25.94
76028	1	L	120	0.013	4	13.10	26.2
7604	1	K	120	0.017	4	16.35	33
76048	1	L	120	0.017	4	16.35	33.00
7605	1	K	120	0.017	4	16.35	33
76058	1	L	120	0.017	4	16.35	33.00
7606	1	K	120	0.013	4	13.07	25.94
76068	1	L	120	0.013	4	13.07	26.2
7607	1	K	120	0.013	4	12.8	25.58
HD 8201	1	A	144	0.015HD	4	16.73	33.46
8300	1	A	144	0.010	4	13.5	25.2
8301	1	A	144	0.015	4	16.73	33.46
8500	1	H	144	0.013	4	13.31	26.62
8501	1	H	144	0.018	4	16.86	33.72

For SI: 1 inch = 25.4 mm, 1 foot = 304.8 mm, 1 lb./lin. ft. = 14.6 N/m, 1 lb. = 4.44 N.

For notes, see Table 3.

TABLE 3—DIMENSIONS AND ALLOWABLE LOADS FOR CROSS RUNNERS

CATALOG NUMBER	NOTE	TYPE	LENGTH (inches)	METAL THICKNESS (inch)	MAXIMUM SPAN (feet)	SIMPLE SPAN UNIFORM LOAD (lb./lin. ft.)	CONCENTRATED LOAD AT MIDSPAN (lb.)
<b>6100 Series</b>							
XL 6110	2	M	12	0.013	1	66.89	66.89
XL 6120	2	M	24	0.013	2	66.89	66.89
XL 6140	2	M	48	0.013	4	12.6	25.2
XL 6190	2	M	72	0.013	4	12.6	25.2
XL 6180	2	M	96	0.013	4	12.6	25.2
<b>6500 Series</b>							
XL 6510	N/A	N	24	0.045	2	72.5	51.3
XL 6520	N/A	N	24	0.045	2	72.5	51.3
XL 6540	N/A	N	48	0.045	4	14.6	14.6
<b>7100 Series</b>							
XL 7128	1	E	24	0.010	2	33	41.6
XL 7148	1	E	48	0.010	4	6	14.2
<b>AL 7200 Series</b>							
XLAL7220	2	B	24	0.021	2	44.45	44.45
XLAL7240	2	B	48	0.021	4	6.33	12.66
<b>SS 7200 Series</b>							
XLSS7220	3	B	24	0.015	2	61.66	61.66
XLSS7240	3	B	48	0.015	4	10.4	20.8
<b>7300 Series</b>							
XL 7318	2	D	12	0.010	1	73.59	36.65
XL 7398	2	D	18	0.010	1.5	73.29	54.97
XL 7360	2	D	20	0.013	1.67	87.58	73.13
XL 7368	2	D	20	0.010	1.67	73.29	61.2
XL 7328	2	D	24	0.010	2	38.63	38.63
XL 7378	2	D	30	0.010	2.5	16.54	18.6
XL 7330	2	D	36	0.010	3	20.83	31.25
XL 7348	2	D	48	0.010	4	8.31	16.62
XL 7342	2	C	48	0.010	4	9.98	19.96
XL 7340	2	A	48	0.010	4	12.25	25.5
XL 7341	2	A	48	0.015	4	16.89	32.78
XL 7357	2	A	60	0.015	5	7.61	19.03
XL 7358	2	A	60	0.015	5	7.61	19.03
XL 7390	2	A	48	0.010	6	3.3	14.38
XL 7390	2	A	72	0.010	4	12.24	25.5
XL 7380	2	A	96	0.010	8	1.57	11
XL 7380	2	A	96	0.010	4	12.12	15.70
<b>7500 Series</b>							
XL 7510	1	H	12	0.010	1	51.83	61.6
XL 7560	1	H	20	0.010	1.67	51.83	61.6
XL 7520	1	H	24	0.010	2	51.83	61.6
XL 7570	1	H	30	0.010	2.5	28.67	53.12
XL 7530	1	H	36	0.010	3	21.03	38.37
XL 7540	1	H	48	0.010	4	10.34	26.71
XL 7541	1	H	48	0.013	4	12.73	32.67
XL 7549	1	H	48	0.018	4	16.42	42.2
XL 7558	1	H	60	0.013	5	5.8	20.9
XL 7590	1	H	72	0.013	4	12.73	32.67
XL 7580	1	H	96	0.013	4	12.73	32.67
<b>7600 Series</b>							
XL 7610	1	I	12	0.015	1	71.66	72.95
XL 7660	1	I	20	0.015	1.67	71.66	72.95
XL 7620	1	I	24	0.015	2	71.66	72.95
XL 7670	1	I	30	0.015	2.5	39.86	46.67
XL 7640	1	I	48	0.015	4	13.53	31.51
XL 7646	1	I	48	0.015	4	13.21	30.77
XL 7645	1	I	48	0.015	4	12.85	29.93
XL 7650	1	I	60	0.015	5	6.09	20.17
XL 7655	1	I	60	0.015	5	5.71	19.15
XL 7657	1	I	60	0.015	5	5.90	19.69
XL 7690	1	K	72	0.013	4	12.59	29.93
XL 7680	1	K	96	0.013	4	12.59	29.93

(Continued)

TABLE 3—DIMENSIONS AND ALLOWABLE LOADS FOR CROSS RUNNERS (Continued)

CATALOG NUMBER	NOTE	TYPE	LENGTH (inches)	METAL THICKNESS (inch)	MAXIMUM SPAN (feet)	SIMPLE SPAN UNIFORM LOAD (lb./lin. ft.)	CONCENTRATED LOAD AT MIDSPAN (lb.)
<b>7600 Series (Continued)</b>							
XL76108	1	J	12	0.015	1	69.69	69.69
XL 76608	1	J	20	0.015	1.67	69.69	69.69
XL 76208	1	J	24	0.015	2	69.69	69.69
XL 76708	1	J	30	0.015	2.5	47.76	59.7
XL 76408	1	J	48	0.015	4	14.11	28.22
XL 76468	1	J	48	0.015	4	13.01	26.02
XL 76458	1	J	48	0.015	4	12.6	25.2
XL 76508	1	J	60	0.015	5	9	23
XL 76558	1	J	60	0.015	5	7	20
XL 76578	1	J	60	0.015	5	7	18
XL 76908	1	L	72	0.013	4	12.6	25.2
XL 76808	1	L	96	0.013	4	12.6	25.2
<b>8200 Series</b>							
XL 8223	2	B	24	0.013HD	2	38.63	38.63
XL 8240	2	B	48	0.013HD	4	12.75	25.5
<b>8300 Series</b>							
XL 8313	2	D	12	0.009	1	45.4	38.11
XL 8323	2	D	24	0.009	2	40.45	58.28
XL 8320	2	A	24	0.011	2	61.33	59.78
XL 8378	2	A	30	0.011	2.5	20.84	31.17
XL 8330	2	A	36	0.011	3	23.11	41.57
XL 8340	2	A	48	0.011	4	12.25	26.42
XL 8341	2	A	48	0.015	4	16.89	32.78
XL 8357	2	A	60	0.015	5	7.47	19.03
XL 8358	2	A	60	0.015	5	7.53	19.03
<b>8500 Series</b>							
XL 8520	1	H	24	0.013	2	58.5	58.5
XL 8540	1	H	48	0.013	4	12.73	27.44

For SI: 1 inch = 25.4 mm, 1 foot = 304.8 mm, 1 lb./lin. ft. = 14.6 N/m, 1 lb. = 4.44 N.

**NOTES:**

- 1 = Single stitched web
- 2 = Double stitched web
- 3 = Available stitched or unstitched
- HD = Environmental hot-dipped galvanized finish

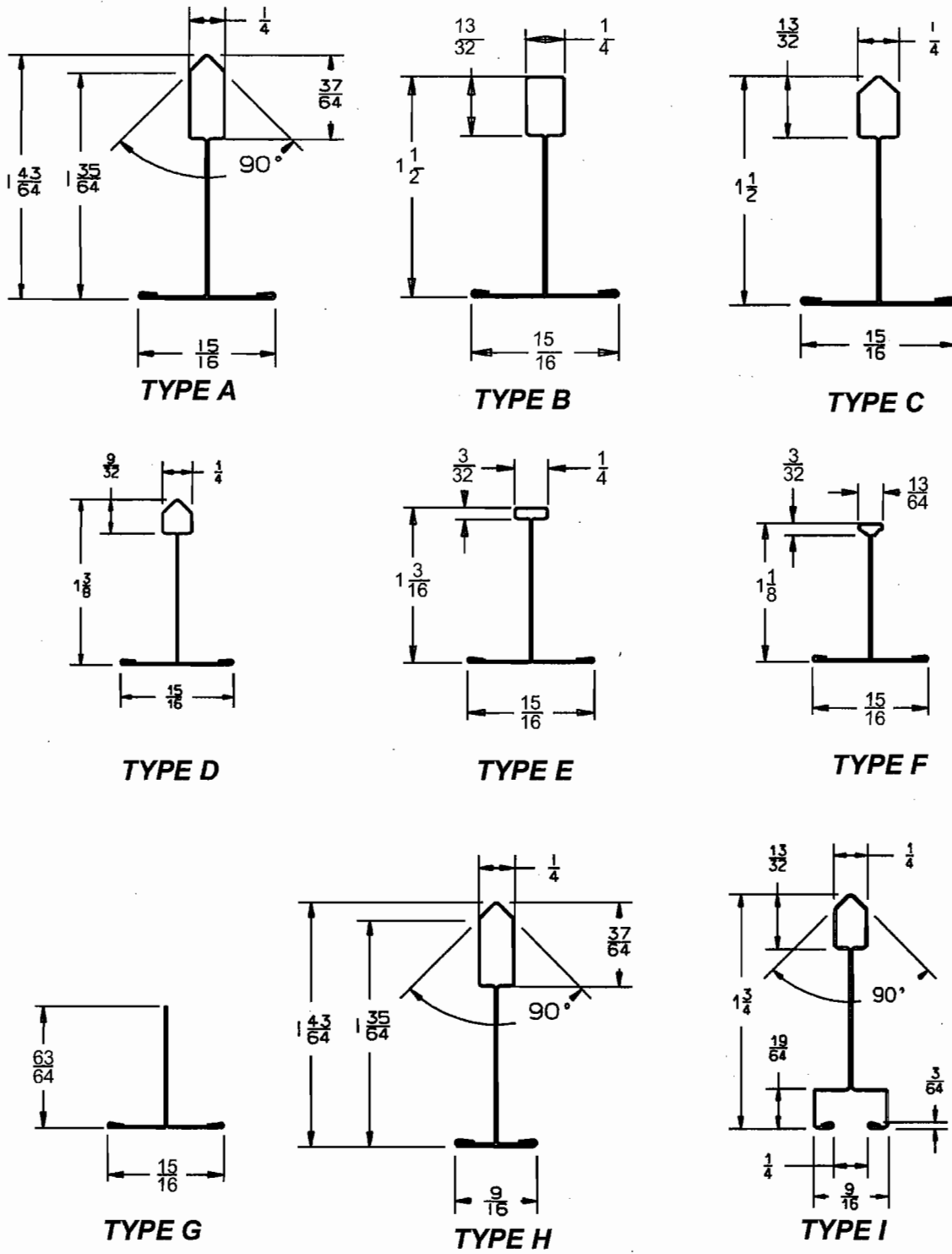

FIGURE 1—RUNNER PROFILES

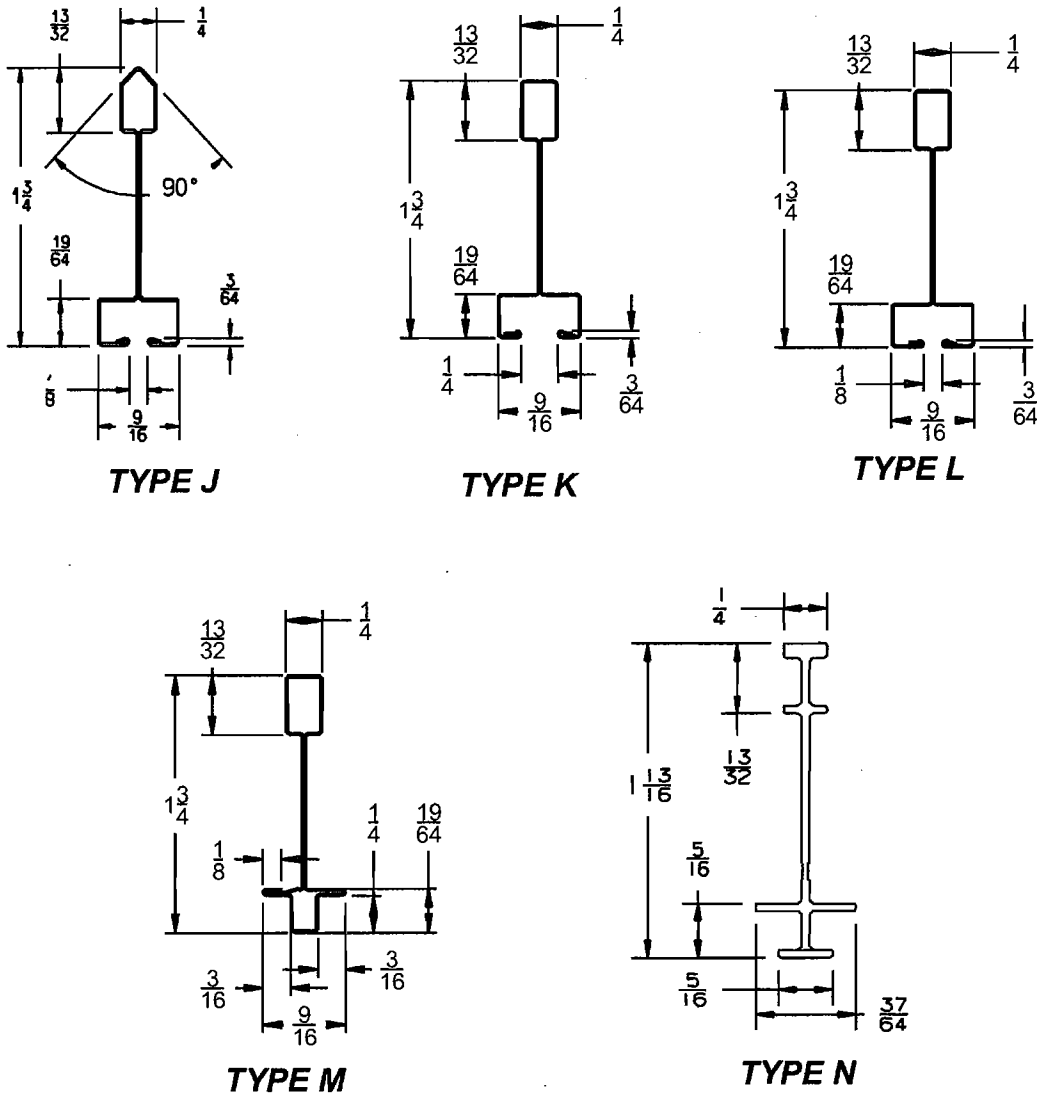
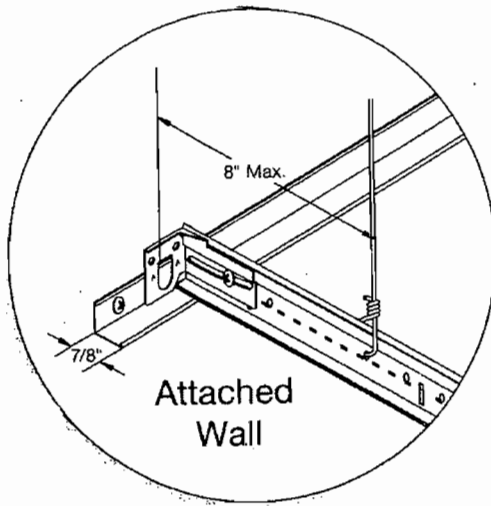
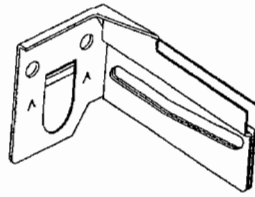
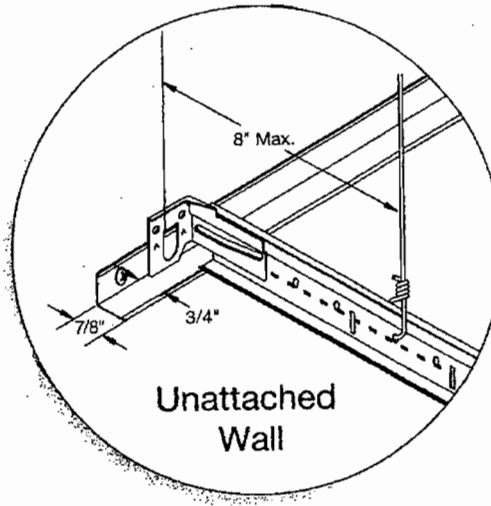

FIGURE 1—RUNNER PROFILES (Continued)



Attached Wall



Unattached Wall

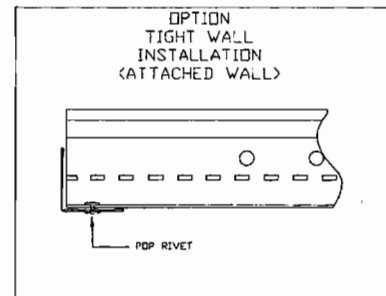
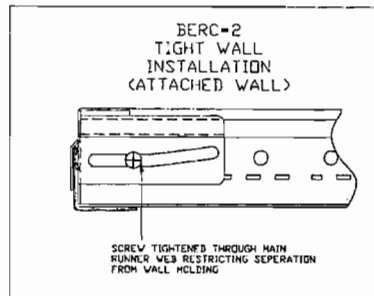
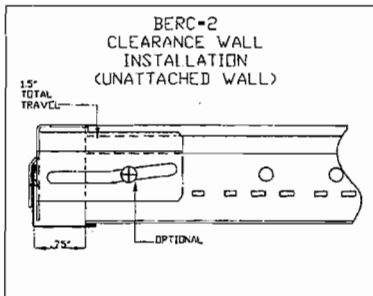
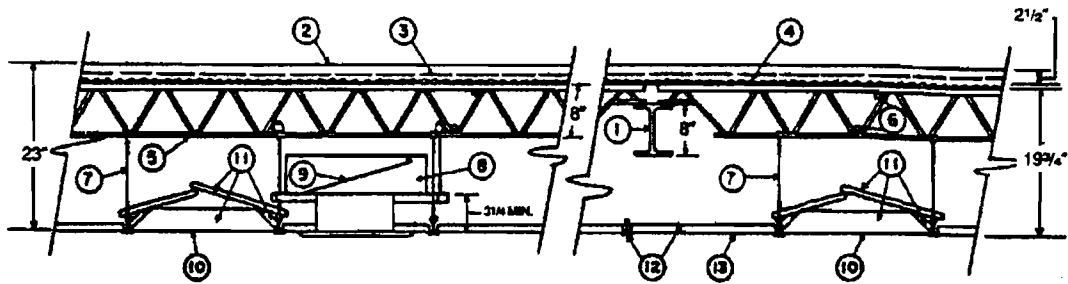

FIGURE 2—BERC-2 CLIP



1. Beam:
2. Normal-weight Concrete
3. Welded Wire Fabric
4. Steel Form Units
5. Steel Joists
6. Bridging
7. Hanger Wire
8. Air Duct
9. Damper: No. 16 MSG minimum galvanized steel, sized to overlap duct opening 2 inches, minimum. Protected on both sides with  $\frac{1}{16}$ -inch-thick ceramic fiber paper laminated to the metal with adhesive and held open with a listed fusible link.
10. Fixtures, Recessed Light
11. Fixture Protection—Batts and Blankets
12. Steel Framing Members—Worthington Armstrong Venture
13. Acoustical Material
14. Hold-down Clips (Not illustrated)

For SI: 1 inch = 25.4 mm.

**FIGURE 3—TWO-HOUR FIRE-RESISTANCE-RATED FLOOR-CEILING ASSEMBLY (REFER TO SECTION 4.6 OF THIS REPORT)**

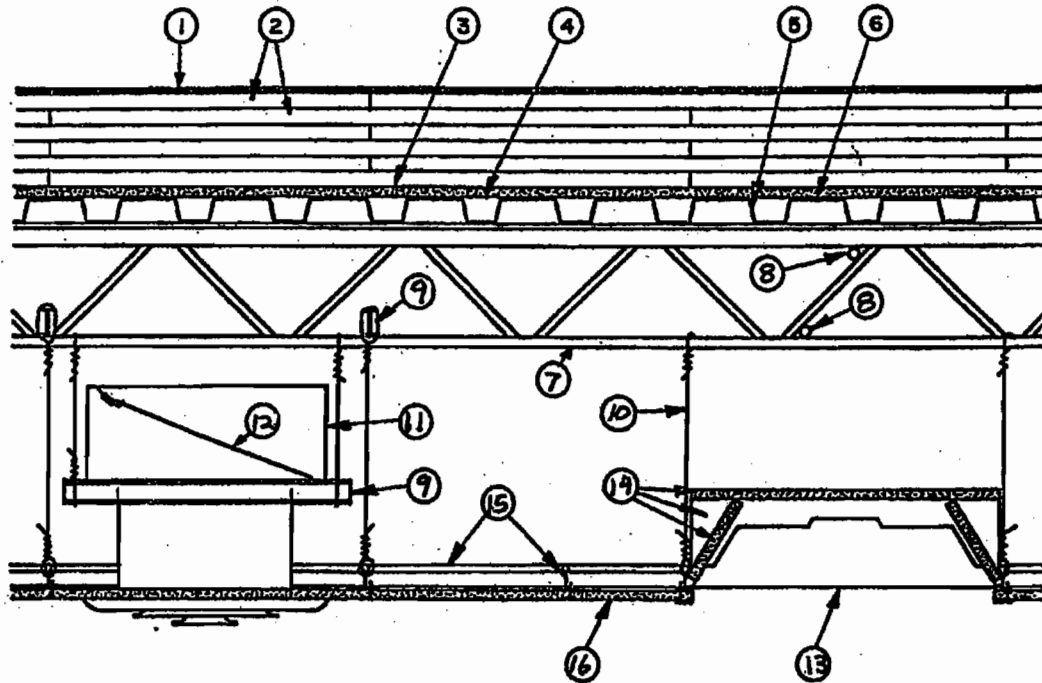

For SI: 1 inch = 25.4 mm, 1 foot = 304.8 mm, 1 psf = 4.88 kg/m<sup>2</sup>, 1 gallon = 3.81 L, 1 sq. ft. = 0.0929 m<sup>2</sup>, 1 psi = 6.89 kPa, 1 lbm = 0.45 kg, 1 sq. in. = 645.16 mm<sup>2</sup>.

1. **Roof Covering:** Roof covering consisting of hot-mopped or cold application materials compatible with insulation(s) described in Item 2 that provide Class A, B or C coverings.
2. **Roof Insulation—Mineral and Fiber Boards:** The boards shall comply with ASTM C 612, Type 1A or 1B; 24-by-48-inch minimum size, maximum size 48 by 96 inches, to be applied in six layers. Boards to be installed perpendicular to gypsum wallboard direction, with end joints staggered 2 feet in adjacent rows. Each layer of board shall be offset, in both directions, from layer below a minimum of 12 inches in order to lap all joints. Minimum board thickness is 1 inch (No limit on maximum overall thickness.)
3. **Sheathing Material (Optional):** Vinyl film vapor barrier, applied with adhesive to the gypsum wallboard. Adjacent sheets overlapped 2 inches.
4. **Gypsum Sheathing:** Water-resistant core gypsum sheathing complying with ASTM C 79. Supplied in sheets nominally 2 by 4 feet to 4 by 12 feet, by nominal  $\frac{5}{8}$  inch thick. Minimum weight is 2.0 psf. Applied perpendicular to the steel roof deck direction with adhesive, or laid loosely. End joints to occur over crests of steel roof deck, with end joints staggered 2 feet in adjacent rows.
5. **Steel Roof Deck:** Minimum 0.019-inch-thick (26 gage), minimum 1-inch-deep, minimum 25-inch-wide, painted or galvanized, fluted steel deck. Flutes shall be approximately 4 inches on center, crests approximately  $2\frac{3}{4}$  inches wide. As an alternate,  $1\frac{1}{2}$ -inch-deep, minimum 18-inch-wide fluted galvanized steel deck is permitted. Minimum 0.029-inch-thick (22 gage) flutes shall be 6 inches on center, crest width ranging from  $3\frac{1}{2}$  to 5 inches. Deck shall be welded to supports with welding washers spaced 12 inches on center. Side lap joints of adjacent units welded or secured together with No. 12 by  $\frac{1}{2}$ -inch self-drilling, self-tapping steel screws midway between steel joists.
6. **Fasteners:**
  - A. **Adhesive (Optional): BMCA Insulation Products Inc.:** May be applied between crests of steel roof deck and gypsum sheathing in  $\frac{1}{2}$ -inch-wide ribbons, 8 inches on center, at 0.4 gallon per 100 square feet. May also be applied in  $\frac{1}{2}$ -inch-wide ribbons, 6 inches on center, at 0.4 gallon per 100 square feet, between gypsum sheathing and vapor barrier, and between gypsum boards and roof insulation when vapor barrier is omitted. May also be applied at the same rate between layers of roof insulation.
  - B. **Mechanical Fastener:** (Not shown) Any steel nail or steel clip designed for the purpose may be used to attach one or more layers of insulation to steel roof deck (through gypsum sheathing). The gypsum sheathing may also be attached directly to the steel roof deck with the mechanical fasteners.
  - C. **Hot Asphalt or Coal Tar Pitch:** (Not shown) May be used as an alternate to adhesive between layers of roof insulation, at a rate not to exceed 35 pounds per 100 square feet.

FIGURE 4—8500 SERIES ONE-HOUR FIRE-RESISTANCE-RATED ASSEMBLY

7. **Steel Joists:** Type 10J4 or 12K1 minimum size. 10K1 size may be used when limited to a span of 12 feet 0 inches, maximum. As an alternate, any LH Series steel joists spanning no greater than 60 feet may be used. For spans greater than 60 feet, LH Series joists may be used, provided their vertical deflection under total load shall not be greater than  $\frac{1}{244}$  of the joist span.
8. **Bridging:** Steel bars,  $\frac{1}{2}$  inch in diameter, welded to top and bottom chords of each joist.
9. **Cold-rolled Channels:** Number 16 MSG cold-rolled steel channels,  $1\frac{1}{2}$  inches deep with  $\frac{9}{16}$ -inch flanges shall be placed on lower chord of joists and secured with 18 SWG galvanized steel wire. Installed perpendicular to joists, the channels shall be located as required to provide hanger wire attachment points.

When steel joists are spaced more than 5 feet on center, two cold-rolled channels shall be placed back to back and tied together with a double strand of 18 SWG galvanized steel wire at 24 inches on center. The double channels installed perpendicular to the joists and spaced a maximum of 48 inches on center may be placed on top of the joists' bottom chord and tied to each joist with a double strand of 18 SWG galvanized steel wire, or suspended below the joists with 12 SWG galvanized steel wire wrapped around the cold-rolled channels and with the other end wrapped around the bottom chord of the joists.

10. **Hanger Wire:** Number 12 SWG galvanized wire shall be twist-tied to steel joists or cold-rolled steel channels. When the ceiling consists of nominal 24-by-24-inch panels or 24-by-48-inch panels, hanger wires shall be spaced a maximum of 48 inches on center on main runners adjacent to cross tee intersections. Hanger wires shall occur at all four corners of light fixtures, at midspan of cross tees adjacent to 4-foot light fixtures and air duct outlets, and adjacent to each main runner splice. When the ceiling consists of nominal 20-by-60-inch panels, hanger wires shall be spaced 40 inches on center along main runners, and one wire shall occur at each corner of light fixtures, at midspan of all cross tees, and adjacent to each main runner splice.
11. **Air Duct:** Minimum 0.019-inch-thick (26 gage) galvanized steel. Total area of duct openings shall not exceed 576 square inches per each 100 square feet of ceiling area. Area of individual duct openings shall not exceed 576 square inches. Maximum opening dimension is 18 inches. Inside and outside faces of duct throat shall be protected with  $\frac{1}{16}$ -inch-thick ceramic fiber paper, laminated to the metal. Maximum dimension of opening is 30 inches. Duct supported by  $1\frac{1}{2}$ -inch-deep, minimum 0.053-inch-thick (16 gage) cold-rolled steel channels spaced not over 48 inches on center, suspended by No. 12 SWG galvanized steel wire.
12. **Damper:** Minimum 0.056-inch-thick (16 gage) galvanized steel, sized to overlap duct opening a minimum of 2 inches. Protected on both sides with  $\frac{1}{16}$ -inch-thick ceramic fiber paper, laminated to the metal, and held open with a fusible link.
13. **Fixtures, Recessed Light:** Fluorescent-lamp-type steel housing, nominally 2 by 4 feet or 20 by 60 inches in size. Fixtures shall be spaced so their total area does not exceed 24 square feet per each 100 square feet of ceiling area. When 20-by-60 inch fixtures shall be used, fixture stabilizers formed from No. 16 gage steel channels, shall be used in addition to the hanger wires at midspan of the cross tees. Fixture shall be wired in conformance with the National Electrical Code. Fixture and ballasts shall be considered for ambient temperature conditions before installation.
14. **Fixture Protection—Acoustical Material—Armstrong World Industries, Inc.:** Type  $\frac{5}{8}$ -inch P (S) or  $\frac{5}{8}$ -inch PC (S) is cut to form a five-sided enclosure, trapezoidal in cross section, approximately  $\frac{1}{2}$  inch longer and wider, and  $\frac{5}{8}$  inch higher, than the light fixture housing. For 2-by-4-foot fixtures, the protection consists of a  $23\frac{3}{4}$ -by- $47\frac{3}{4}$ -inch top piece, two  $5\frac{7}{8}$ -by- $47\frac{3}{4}$ -inch side pieces, and two  $4\frac{1}{2}$ -by- $23\frac{3}{4}$ -inch end pieces. For 20-by-60-inch fixtures, the protection consists of a nominal 20-by-60-inch top piece, two nominal 6-by-60-inch side pieces, and two nominal  $4\frac{1}{2}$ -by-20-inch end pieces. The top edge of each fixture protection side piece may be provided with a 1-inch-deep-by-maximum-20-inch-long notch near its midpoint. The side and top pieces shall be laid in place and the end pieces shall be held in place with three 8d nails spaced 8 inches on center. (S) - Surface perforations.
15. **Steel Framing Members—Armstrong World Industries, Inc.:** Type 8500 systems with a  $\frac{15}{16}$ -inch-wide flange grid shall be used. Main runners, nominally 12 feet long, shall be spaced 4 feet on center. Cross tees, nominally 4 feet long, shall be installed perpendicular to main runners and spaced 2 feet on center. Cross tees, nominally 2 feet long, shall be installed perpendicular to 4-foot cross tees and spaced 4 feet on center. Grid modules containing light fixtures shall employ a fixture-centering clip at each corner. The No. 24 gage electrogalvanized steel clip is nested on the flange of the intersecting grid tees, has two  $1\frac{7}{16}$ -inch-long legs with their sides perpendicular to each other, and has a U-shaped return at the top of each leg for engaging over the bulb of the intersecting grid tees.
16. **Acoustical Material:** Nominal 24-by-24-inch or -48-inch lay-in panels. Border panels shall be supported at walls by minimum 0.016-inch-thick (26 gage) painted steel angles with  $\frac{7}{8}$ -inch legs; or, minimum 0.016-inch-thick (26 gage) painted steel channels,  $1\frac{1}{8}$  inches deep with  $\frac{7}{8}$ -inch flanges.
17. **Hold-down Clips:** (Not shown) Number 24 MSG spring steel, placed over cross tees at 2 feet on center.

FIGURE 4—8500 SERIES ONE-HOUR FIRE-RESISTANCE-RATED ASSEMBLY (Continued)